

Dynamic Loads Affecting Artillery Launcher Crew¹

Jerzy Jackowski / Leon Prochowski / Jerzy Walentynowicz / Andrzej Żuchowski

Wojskowa Akademia Techniczna, ul. Kaliskiego 2, 00-908 Warszawa

POLAND

jj@wme.wat.edu.pl / a.zuchowski@wme.wat.edu.pl

ABSTRACT

Results of the studies on the dynamics of three-axial off-road truck, where open load-carrying body was replaced with artillery launcher, were presented. This change resulted in significant increase of carrying system load and changes to vehicle structure were required. On the basis of experimental study results and simulating calculations, new characteristics of elasticity and absorption forces in the suspension of wheels, cabin and crew seats were selected. In the characteristics selection process, special attention was paid to minimise dynamic loads of vehicle carrying system, to limit the effect of lost ground-wheel contact and to limit vehicle vibrations, especially vibrations affecting the crew. Suggested changes to vehicle structure resulted in considerable reduction of dynamic loads affecting the crew of the launcher in different operating conditions. Gained development was evaluated by means of driving comfort indexes, formulated in obligatory standards.

1. INTRODUCTION

Due to tactic advantages of BM-21 artillery launcher works have been undertaken in many countries in order to modernize it. BM-21 launchers used by Polish Army were installed on imported URAL 375 (Fig.1a) vehicle chassis, which is no longer manufactured. So works have been undertaken leading to replace that chassis with a new structure of one of the vehicles available in the country.

In order to adjust a new vehicle to transport BM-21 launcher, STAR 1366 truck and off-road vehicle of universal use, i.e. with an open load-carrying body (fig. 1b), has been modernized. Planned structural changes to STAR 1366 vehicle chassis should provide a possibility of transporting a launcher of weight significantly loading the rear part of the vehicle carrying system. The improvement of crew driving comfort was an important objective. It was planned to be achieved through changes to the frame structure and driving wheel suspension, crew cabin and seat suspensions. As a result of the modernization works a prototype of STAR 1466 vehicle with a launcher was built (fig. 1c). In order to improve the crew driving conditions a flexibly suspended six-seat cabin was introduced.



Figure 1: A launcher on Ural 375D vehicle (a), a vehicle before modernization (Star1366) (b) and modernized version (Star 1466) (c)

¹ The Work was prepared according to Target Project No 148170/C-T00/98, financed by Scientific Research Committee.

Dynamic Loads Affecting Artillery Launcher Crew

New chassis has different dynamic features compared to the one used so far. So the studies were prepared to identify dynamic loads affecting the launcher crew in various operation conditions. Obtained values and driving comfort factors were compared to valid standards.

2. DRIVE DYNAMICS MODELS AND MODEL VERIFICATION

Structural changes to a chassis of a modernized vehicle were preceded by a wide scope of simulating calculations. The most important project analyses, including identification of favourable launcher installation on the vehicle frame, selection of driving wheel suspension characteristics in the aspect of minimization of dynamic loads of a launcher vehicle frame and in order to obtain necessary crew driving comfort, were prepared on the basis of model test results. Models used for the tests are shown on figures 2 and 3 and were described in previous works [2,3]. Two models were built. The first one corresponded to the characteristics of a vehicle with an open load-carrying body and the latter one included launcher installation replacing the open load-carrying body.

In the model creation process, the vehicle was replaced with an equivalent system of non-deformable solids, connected with weightless viscoelastic couplers (fig. 2). Figure 3 shows the forces affecting the frame that were considered during the analysis of the dynamic load condition of the carrying and driving systems in the considered model of a vehicle with an open load-carrying body and a launcher. Forces appearing in the connections between the cabin, engine, open load-carrying body, driving wheel suspensions units and the launcher and the frame were used to calculate frame deformation moments in various vehicle operation conditions. Flexible suspension (with existing displacement limiters) front and rear wheel axles, the cabin, driving block, the launcher (or an open load-carrying body) as well as flexible-suppressing tyre features were taken into consideration.

Verification of dynamics model of open load-carrying body vehicle drive was carried out by comparing the object and model response to forced jumps. Example measurement and calculation results are specified on Figure 4. Consistency of model and object response course was obtained as far as the amplitude and frequency of free vehicle vibrations are concerned, and it confirmed the correctness of models prepared [1]. After the verification tests of the open load-carrying body vehicle model, a launcher vehicle model was prepared. The launcher solid was replaced the open load-carrying body (fig. 2b). A number and spacing of new solid supporting points on the vehicle frame was changed respectively. This model also included a crew cabin with two rows of seats.

Prepared models of launcher vehicle drive dynamics went through a wide scope of simulation tests that lead to:

- identification of flexible-damping element characteristics advantageous to the modernized vehicle (driving wheel suspension, cabin and seat suspension);
- identification of driver and crew drive comfort indexes.

In the process of selection of advantageous suspension characteristics, special attention was paid to minimization of dynamic loads affecting the vehicle support system frame, limitation of wheel-ground contact loss effect, limitation of vehicle vibrations, and especially to accelerations of cabin floor underneath driver's and crew seats, vertical accelerations of the frame above the front wheel axle and accelerations of longitudinal-angular vibrations of the launcher around its mass center. Detailed description of these calculations is presented in [1-4].

Simulation tests, carried out during straight vehicle motion on the asphalt surface road in "good" and "devastated" condition and unsurfaced road (soil-surfaced road) showed that maximum frame calculation values appear in place of rear axle suspension (point M23 on fig.3). Launcher installation results in very high loads focused on the frame in sections W1 and W2 in these driving conditions. These loads are 3 times as high as the ones resulting from the installation of the open load-carrying body. When testing the determining input functions on a vehicle, driving through single roughness that simultaneously affect left side and right side vehicle wheels was simulated. Obtained calculation results indicate that – in these kind of driving conditions – values of reactions determined in W1 and W2 frame sections are significant, about 4 times as high as the values of reactions in the suspension points of open load-carrying body (SK1

...SK6). Minimization of these unfavourable load values was achieved mostly due to introduced changes to driving wheel suspension characteristics.

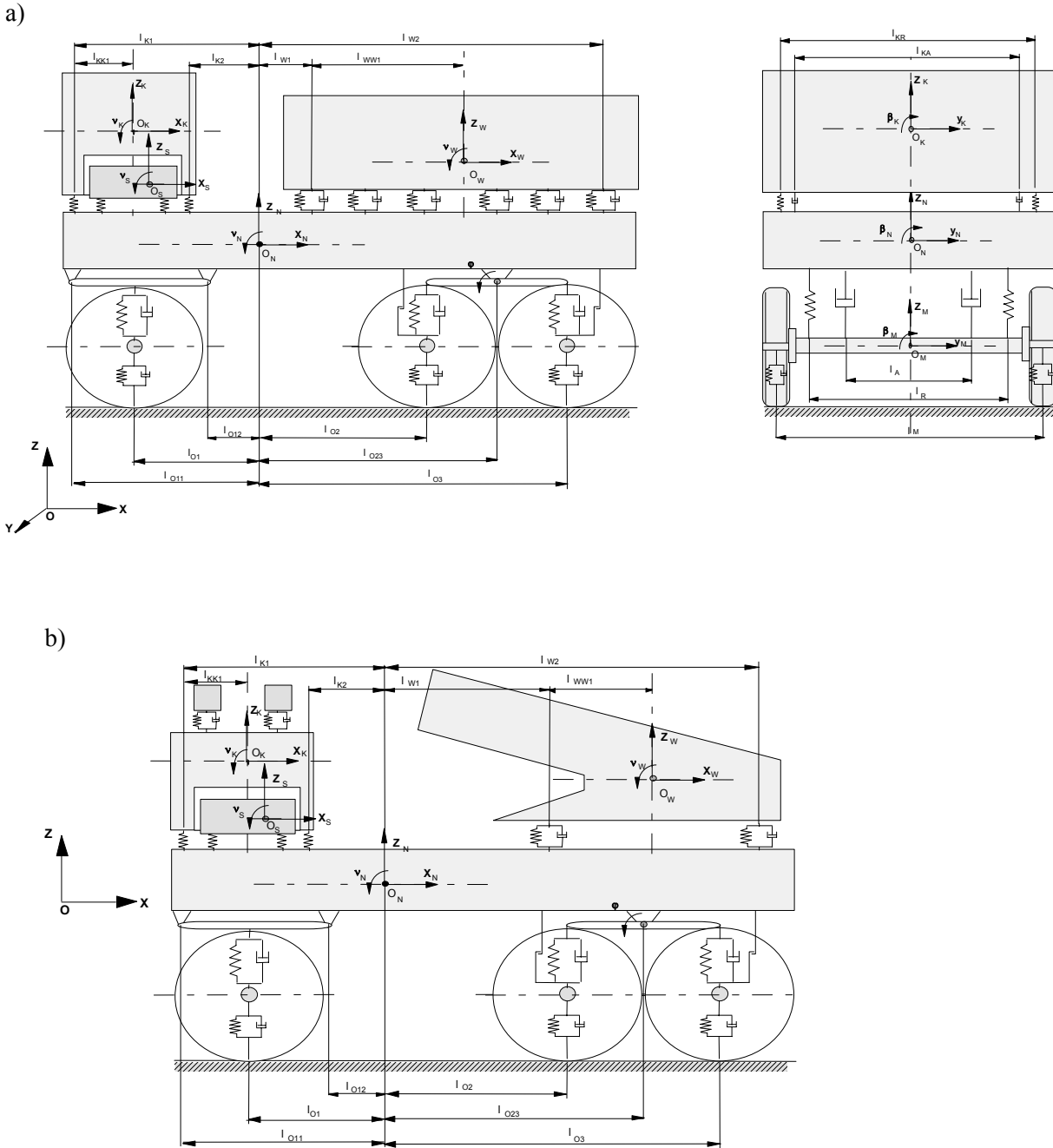

Figure 2: Open load-carrying body truck model (a) and with launcher (b)

Dynamic Loads Affecting Artillery Launcher Crew

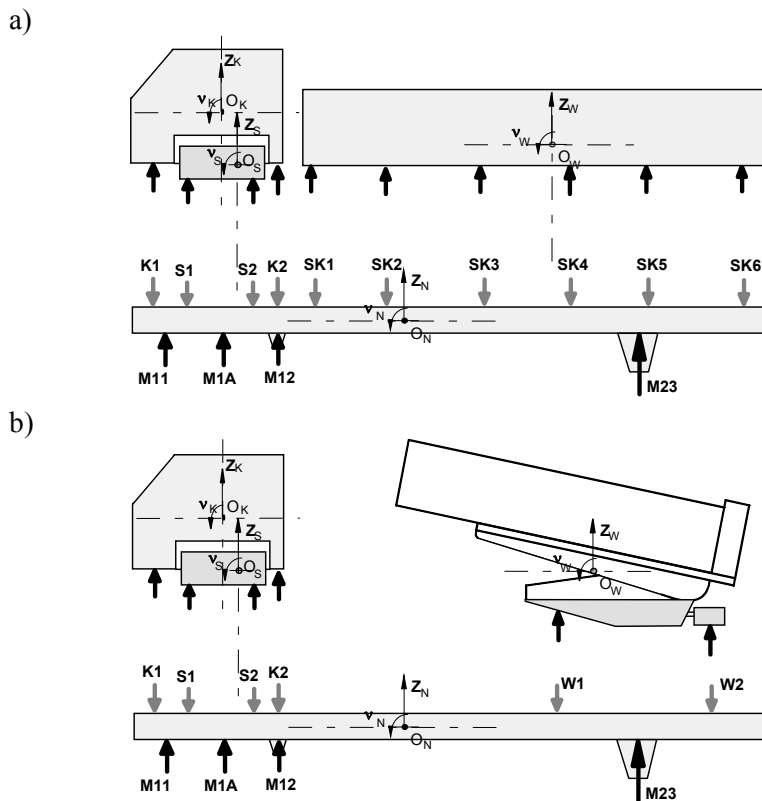

Figure 3: Vehicle frame load diagram: with open load-carrying body (a) and with installed launcher (b)

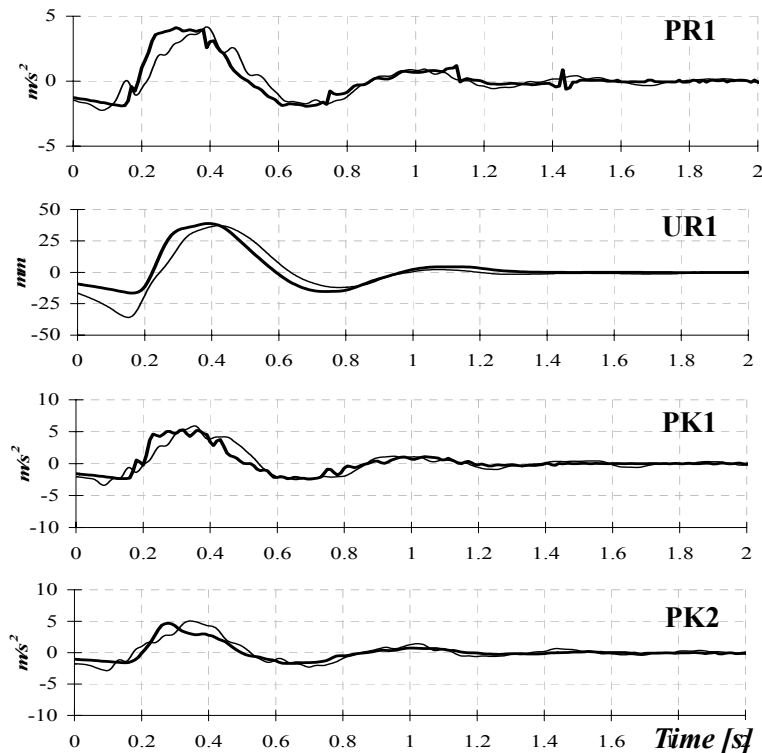

Figure 4: Realizations of front vehicle part vibrations; thin lines – average course of several object vibration measurements, thick line - simulation result; *PR1*- vertical accelerations of the frame above the front wheel axle, *UR1*- front suspension spring deflection, *PK1*- vertical cabin accelerations above its front suspension, *PK2* – vertical accelerations of the cabin above its rear suspension

3. SELECTION OF DRIVER CABIN SUSPENSION CHARACTERISTICS

Changing the course of driving wheel suspension characteristics positively affected the reduction of vehicle driving and supporting system loads. Required load-carrying ability was provided and minimization of its deflection during shooting. However introduced changes turned out not to be sufficient in the aspect of minimization of dynamic loads the launcher crew is subject to while driving. So there was an effort to improve the driving comfort of the crew by changing the characteristics of the cabin suspension and the seat suspension in the driver’s cabin. Suggested cabin suspension characteristics are shown on Figure 5. Driver’s seat suspension change included the replacement of mechanical suspension with the pneumatic one, which can be characterized by a lower suspension stiffness value (stiffness value change from 40000 N/m to 20000 N/m) and higher damping (damping value change from 2500 Ns/m to 4000 Ns/m).

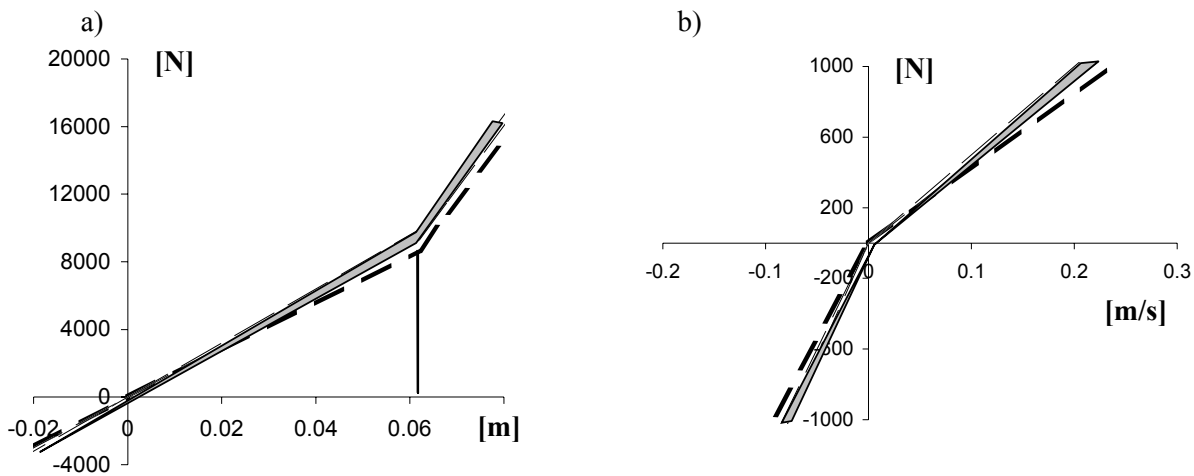

Figure 5: Characteristics of elasticity (a) and damping (b) of rear vehicle cabin suspension; broken line – nominal characteristic shape; full line – area of favourable characteristics course

The effects of changes made to the characteristics of cabin suspension and seat suspension in the driver’s cabin can be evaluated on the basis of calculation results – some of them are presented in Table 1 as an example. The calculations confirmed a possibility of improving the drive comfort through the modernization of vehicle cabin suspension.

Table 1: Comparison of accelerations on the seats in the cabin based on the suspension of nominal and modified elasticity and damping characteristics in the launcher vehicle model

Driving conditions	Location	Standard deviation value of accelerations		Increase of acceptable driving time [%]
		Calculations for characteristics before modernization	Calculations for characteristics after chassis modernization	
Asphalt road, speed 90 km/h, launcher without shells	Center of mass of a person seating on the front seat [m/s ²]	1,36	1,21	31 %
	Center of mass of a person seating on the rear seat [m/s ²]	1,41	1,20	
Dirt road, speed 50 km/h, launcher with shells	Center of mass of a person seating on the front seat [m/s ²]	2,90	2,62	30 %
	Center of mass of a person seating on the rear seat [m/s ²]	2,63	2,32	

Dynamic Loads Affecting Artillery Launcher Crew

4. EXPERIMENTAL DRIVING COMFORT TESTS

Proposed changes to the cabin and seat suspensions were checked during the road tests of the modernized vehicle. The diagram of measurement system used is shown on Figure 6. The driving comfort analysis was carried out on the basis of driving comfort indexes given in ISO 2631. The test was carried out on two asphalt road sections, one of them defined as a good surface road and the latter one as a road of devastated surface (asphalt with high number of fissures). The following driving speed values were assumed: $V=30, 50, 70$ km/h. Driver's seat vibrations were registered by means of three sensors of accelerations in three mutually perpendicular directions. Examples of measurement results are shown on Figure 7.

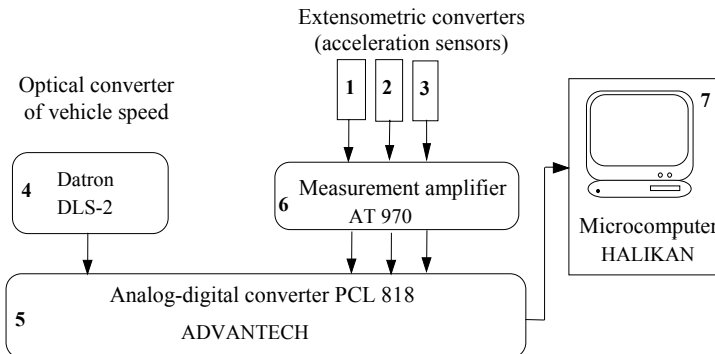

Figure 6: Measurement system diagram

Discomfort limit criterion according to ISO 2631 was assumed as a basis of the evaluation of vibration effect on a human body. This criterion made a basis for determination of the so-called acceptable time of vibration effect on a man (driver's driving time). In modernized vehicle (new wheel and cabin suspension, 6-seater cabin, launcher installed) significant reduction of vehicle vibration level affecting the driving comfort was obtained. Reduction of vibrations in the cabin and on the seats, in spite of the increase of dynamic loads of the driving and suspension systems, allowed for significant improvement of vehicle driving comfort for a driver and the whole crew [3,4]. The biggest progress was achieved in the aspect of vibration reduction on a driver's seat when driving on a bad quality surface. This progress, which can be estimated by the so called acceptable human vibration effect time according to ISO 2631, amounts to tens of percentage units and it can be confirmed by the results specified in Table 2.

Table 2: Acceptable driver vibration effect time according to ISO 2631

Road surface	Speed [km/h]	Vibration effect direction					
		Vertical [min]		Transverse [min]		Longitudinal [min]	
		S*	W*	S	W	S	W
Vehicle without load (launcher without shells)							
Good quality asphalt	30	480	480	480	480	480	480
	50	233	480	480	480	480	480
	70	405	400	480	480	480	480
Bad quality asphalt	30	270	480	480	480	480	480
	50	101	207	480	480	480	480
	70	94	140	480	480	480	480
Vehicle with load (launcher with shells)							
Good quality asphalt	30	480	480	480	480	480	480
	50	480	480	480	480	480	480
	70	356	480	480	480	480	480
Bad quality asphalt	30	480	480	480	480	480	480
	50	120	285	480	480	480	480
	70	131	215	480	480	480	480

S* - vehicle with open load-carrying body , W* - vehicle with launcher

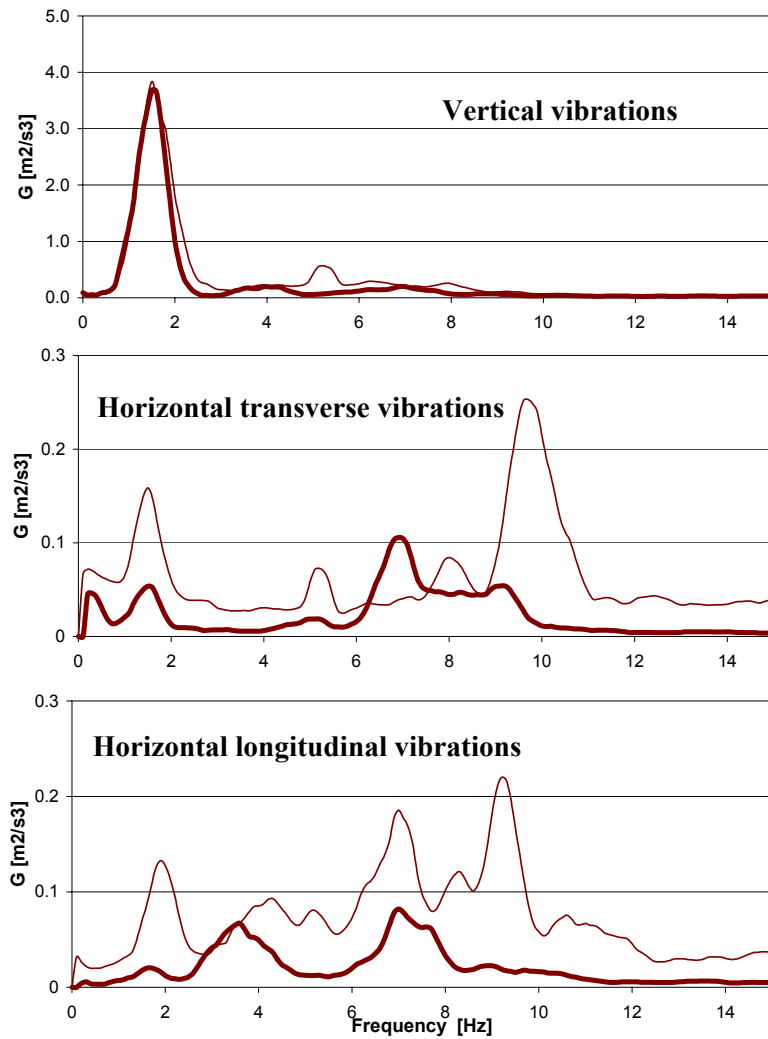

Figure 7: Specification of acceleration spectrum density estimator courses on a driver's seat of STAR1366 vehicle with load/shells (speed 70km/h, bad quality surface); thin line – vehicle with open load-carrying body, thick line – vehicle with launcher, cabin and seat suspension after modernisation

5. DETERMINING INPUT FUNCTION EFFECTS

The road tests were supplemented with tests drives on specially prepared artificial road roughness. Results of the measurements taken during these drives estimated the dynamic features of a vehicle with modified cabin and seat suspension characteristics. Dimensions and example of roughness setting is presented on Figure 8. Dynamic vehicle loads resulted from driving through the road roughness that are distributed in a way that causes significant vertical and transverse (angular) vibrations were observed. Examples of measurement results are presented on Figure 9.

Dynamic Loads Affecting Artillery Launcher Crew

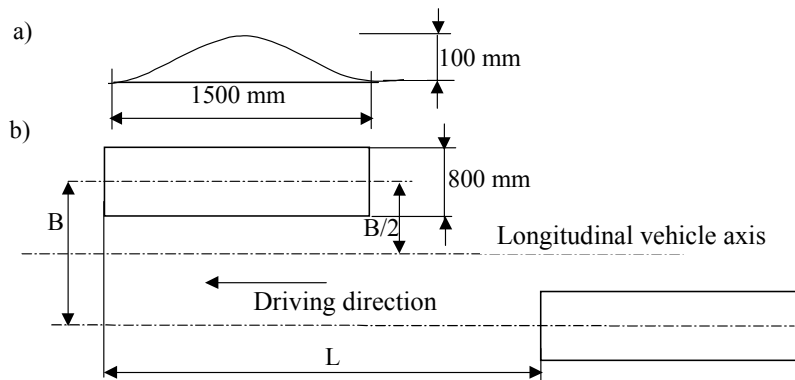

Figure 8: Sinusoidal roughness distribution diagram; a) roughness profile outline, b) roughness distribution at asymmetric input function; L – length between the front wheel axle and rear suspension support axis, B – front wheel spacing

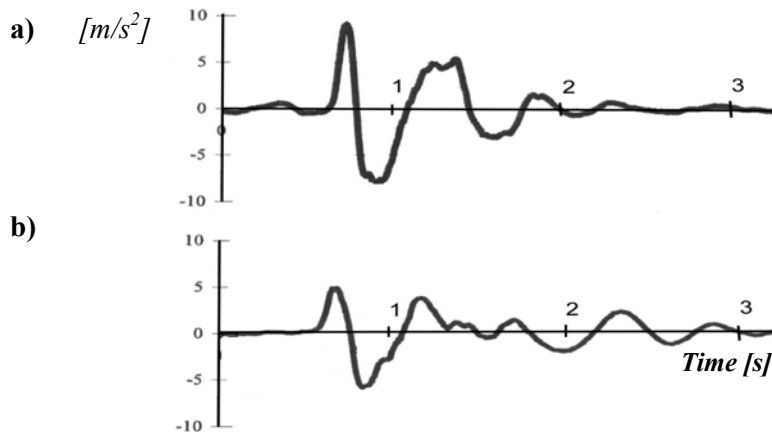

Figure 9: Realizations of vertical vehicle frame accelerations above the front wheel axis during driving through sinusoidal roughness, V=30 km/h; a) vehicle with open load-carrying body (before modernization), b) vehicle with launcher (after modernization)

In spite of a low height of roughness used for the tests (10 cm), the dynamic effect on the vehicle is very high. Driving through such roughness at the speed of 15 km/h causes significant chassis accelerations that amounted to app. 10 m/s^2 in the vehicle before modernization. Such high acceleration values result in significant dynamic driver's body loads, inducing the reduction of driving speed. Significantly lower chassis accelerations were observed in the modernized vehicle compared to the one before modernization. The results of the vehicle dynamics tests in such conditions confirmed the correctness of selected wheel suspension characteristics.

The results of the research carried out by the team of the Institute of Mechanical Vehicles and Transport of Military Academy of Technologies (WAT), included in unpublished reports of *Target Project no 148170/C-T00/98*, financed by the Scientific Research Committee, were used in this work. These reports were prepared by: Dr Eng. Jerzy Jackowski, Dr Eng. Krzysztof Jędrzejczyk, Dr Eng. Tomasz Jędrzejczyk, M.Sc. Eng. Witold Luty, M.Sc. Eng. Sebastian Ławniczak, Professor Dr Eng. Leon Prochowski, M.Sc. Eng. Jerzy Śmietanka, Dr Eng. Andrzej Żuchowski.

6. SUMMARY

The results of the tests of modernized vehicle with a launcher confirm that significant progress in the structure improvement progress was achieved:

- significant reduction of chassis vibrations, reduced by over 30% in the modernized vehicle compared to the one before modernization;
- high driving comfort index values were achieved in spite of unfavourable load arrangement (launcher).

LITERATURE

- [1] Jackowski J., Prochowski L.: The Analysis of Truck and Off-Road Vehicle Suspension Characteristics Improvement, WAT Bulletin no 4/2001
- [2] Jackowski J., Prochowski L.: The Analysis of Chassis Configuration Effect on the Load Condition and Vibrations of Three-Axle Truck, VII IPM International Symposium: „Mechanical Vehicle Structure and Operation Improvement, Warsaw – Rynia, 1999
- [3] Jędrzejczyk K.J., Jędrzejczyk T.A., Prochowski L.: Model Studies on Truck Suspension in the Driving Comfort Aspect, The Folder of Scientific Committee on Automotive Problems, Polish Academy of Science (PAN), Book 18, VII International Scientific Conference: ”Simulation Tests in the Automotive Technologies”, Kazimierz Dolny, 1999
- [4] Jędrzejczyk K.J., Jędrzejczyk T.A., Prochowski L.: The Effects of Middle and Rear Driving Axle Suspension Damping on the Driving Comfort in Three-axle Truck, II Conference: ”Safety Issues in Automotive Vehicles”, Kielce, 2000

Dynamic Loads Affecting Artillery Launcher Crew

Detailed Analysis or Short Description of the AVT-110 contributions and Question/Reply

The Questions/Answers listed in the next paragraphs (table) are limited to the written discussion forms received by the Technical Evaluator. The answers were normally given by the first mentioned author-speaker.

P4 J. Walentynowicz, J. Jackowski, L. Prochowski, A. Zuchowski ‘Dynamic Loads Affecting the Artillery Launcher Crew’ (Mil TU, PL)

This paper typically illustrates the re-engineering techniques coupled with a habitability target, namely the reduction of the vibration levels in different operating conditions: the BM-21 artillery launcher had to be installed on a STAR 1366 truck instead of the obsolete URAL 375 vehicle chassis. . The driving comfort analysis was carried out on the basis of driving comfort indexes given in ISO 2631, the redesigned system tested on well defined roads leading to a satisfactory and substantial 30 % reduction of the vibrations.

Discussor’s name: J. Vantomme

Q. For the test with the 10cm elevation, the acceleration of 10m/s^2 was measured on the wheel-axis. Is this location a good choice in order to conclude something about the cabin crew comfort?

R. The transducers of vibration were mounted on the frame above the axis. Lower acceleration of the same frame increases torsion in the crew cabin.